



TECHNICAL REPORT 3  
MECHANICAL SYSTEMS  
EXISTING CONDITIONS EVALUATION

Prepared by Patrick B. Murphy  
December 8, 2006

The Pennsylvania State University  
Department of Architectural Engineering  
Senior Thesis

Faculty Advisor:  
Dr. James D. Freihaut

## TABLE OF CONTENTS

---

| SECTION   | PAGE |
|---|------|
| Executive Summary.....                          | 1    |
| Design Objectives.....                          | 2    |
| Overview of Mechanical System Design:           |      |
| Design Conditions.....                          | 3    |
| Air Side Systems.....                           | 5    |
| Water Side Systems (Chilled Water).....         | 7    |
| Water Side Systems (Heating Hot Water).....     | 7    |
| ASHRAE Standards Compliance:                    |      |
| ASHRAE Std. 62.1 - 2004.....                    | 13   |
| ASHRAE Std. 90.1 - 2004.....                    | 14   |
| LEED Green Building Rating Compliance.....      | 17   |
| Lost "Rentable" Space.....                      | 21   |
| Mechanical System First Cost Estimate.....      | 22   |
| Mechanical System Operating Cost Estimates..... | 23   |
| Design Critique.....                            | 24   |
| References.....                                 | 26   |

## EXECUTIVE SUMMARY

The Sorenson Language and Communication Center (SLCC) on the Gallaudet University campus in Washington, DC is a one-of-a-kind facility designed for the deaf. Its visu-centric design appeals to the visual communication and way of being within the deaf culture. The owners want the building to be an example not only for other deaf building projects, but also for its energy efficiency and sustainability. The mechanical system in particular is charged with meeting these criteria.

The 87,000 SF facility is served by six (6) Trane M-Series Climate Changer Air Handling Units. Each unit serves a distinct zone within the facility that is unique in use and occupation schedule. The spaces served include classrooms, offices, conference rooms, computer labs, media studios, therapy rooms, audiology labs, and typical support spaces. VAV terminal units with hot water reheat control airflow and supply air temperature to each zone. Chilled water from the Central Utilities Building directly serves the cooling coils in the system. High pressure steam service also comes from the Central Utilities Building and heats the heating hot water and domestic hot water through heat exchangers.

The ventilation rate procedure explained in ASHRAE Std. 62.1 Section 6.2 was used to evaluate the HVAC design of the SLCC. The building envelope and lighting power density requirements explained in ASHRAE Std. 90.1 Sections 5 and 9 were also used to evaluate the design of the SLCC. Additionally, the LEED-NC V2.2 and V2.1 Reference Guides were utilized as well to compare the design of the SLCC for its compliance with each standard. Finally, Carrier's Hourly Analysis Program (HAP) 4.2 was used to build an energy model of the building for analysis. Supplemental analyses for lost "rentable" space and mechanical system first cost were conducted. The input numbers were derived from mechanical drawings, narratives, and calculations provided by the primary architects and MEP engineers at SmithGroup.

The calculations and evaluations performed in this report show that the design for the SLCC meets the criteria for ASHRAE Std. 90.1-2004 compliance, but not Std. 62.1 compliance. The facility would gain a LEED Certified Rating per LEED NC V.2.2. All assumptions, procedures, calculations, analyses and conclusions regarding the design of the SLCC mechanical system may be found within the previous technical reports.

This report finds that the overall the design of the SLCC mechanical system is efficient and practical. Energy saving equipment such as variable speed drives for fan and pump motors and energy saving techniques such as zoning help reduce total energy consumption. Also, the building envelope, glazing, and roofing decisions reduce energy lost/gained from the environment. However, there is room for improvement in the energy efficiency, acoustics, and system access of the SLCC. The goal for this thesis will be to improve the energy efficiency of the building and to address these acoustical issues.

## DESIGN OBJECTIVES

The design of the Gallaudet University Sorenson Language and Communication Center (SLCC) was based on a balance of energy efficiency, cost, and acoustics while meeting ventilation, energy, refrigeration, and fire protection codes and standards. The mechanical system is tagged with the responsibility to effectively heat and cool the 87,000 SF facility while meeting these requirements. The entire design of the facility is intended to garner a LEED v.2.0 Certified Rating.

SmithGroup performed the primary architectural and MEP engineering services for the SLCC. The design only needed to meet DC Codes, which referred to ASHRAE Standards 15-1994, 55-1992, 62.1-1989, 90.1-1989. However, LEED v.2.0 requires compliance with ASHRAE Standards written in 1999 and therefore the SLCC is designed to these criteria instead of DC Codes. Please note that this thesis evaluates the building design against 2004 editions of the ASHRAE Standards and LEED NC v.2.1.

Some of the specific mechanical design criteria include:

- Efficiently condition the spaces within the SLCC. This includes air-side economizer, AHU zoning, occupancy sensors, etc.
- Provide adequate acoustics for sensitive spaces such as classrooms, Audiology and Hearing Science Labs, Speech and Language Sciences Lab, and therapy rooms. These spaces are intended to be at or below NC-25.
- Provide adequate indoor air quality by complying with the IMC-2000 and ASHRAE Std. 62.1-1999; exhausting toilet rooms, rooms with large-format copiers and kitchens; effectively filtering outdoor air and mixed air; and maintaining positive pressurization inside the building.
- Utilize central utilities from the campus Central Utilities Building including chilled water (43°F) and steam (100 psig) to eliminate the need for redundant systems.
- Reduce power use by the equipment by employing variable frequency drives on fan motors.
- Minimize rooftop equipment for aesthetic and service-life purposes. This equipment is limited to exhaust fans on the third floor roof or near exhaust louvers on the side of the building. All equipment is particularly restricted from installation on the second floor roof because of sightlines from the third floor balcony of the atrium to this area.
- Distinct zones for scheduling control of the system. The SLCC includes classroom space, offices, a clinic, an atrium, and computer labs. The goal is to isolate high density spaces to reduce overall building ventilation instead of zoning both high and low density spaces. This avoids a penalty required to properly ventilate the low density spaces due to the primary outdoor air fraction ( $Z_p$ ).

Other design criteria for synergy with other disciplines include:

- Minimize heat loss through exterior walls by meeting ASHRAE Standards for wall construction overall u-values, and including language in the specs for proper construction to minimize exfiltration. Also the design should strategically place glazing to minimize solar heat gain and heat transfer from the interior.
- Reduce solar radiation heat gain to the building by using highly reflective roofing materials.
- Locate the outdoor air intake away from pollutant sources such as cars in parking lots.

## MECHANICAL SYSTEM OVERVIEW

Gallaudet University's future Soreson Language and Communication Center will be served by six AHUs that serve distinct zones within the building (see figure 1) based on occupancy schedules and space types. These AHUs are served by hot water heating coils and chilled water cooling coils. Chilled water service is to be provided from the campus chiller plant while hot water is produced by a plate and frame heat exchanger served by campus steam. With the exception of AHU-2, the air handlers serve VAV terminal units with and without hot water reheat. AHU-2 serves the atrium, however, and provides a constant volume air supply to the large, open space. All return air is directed back to the air handler via transfer ducts and plenum returns. Several support spaces above grade are served by fan coil units (FCUs) and the computer server room (3224) is served by a computer room air conditioning unit (CRAC). Below grade, unit heaters and a FCUs condition mechanical spaces. Secondary direct digital controls (DDCs) direct operation of VAVs, FCUs, and other equipment.

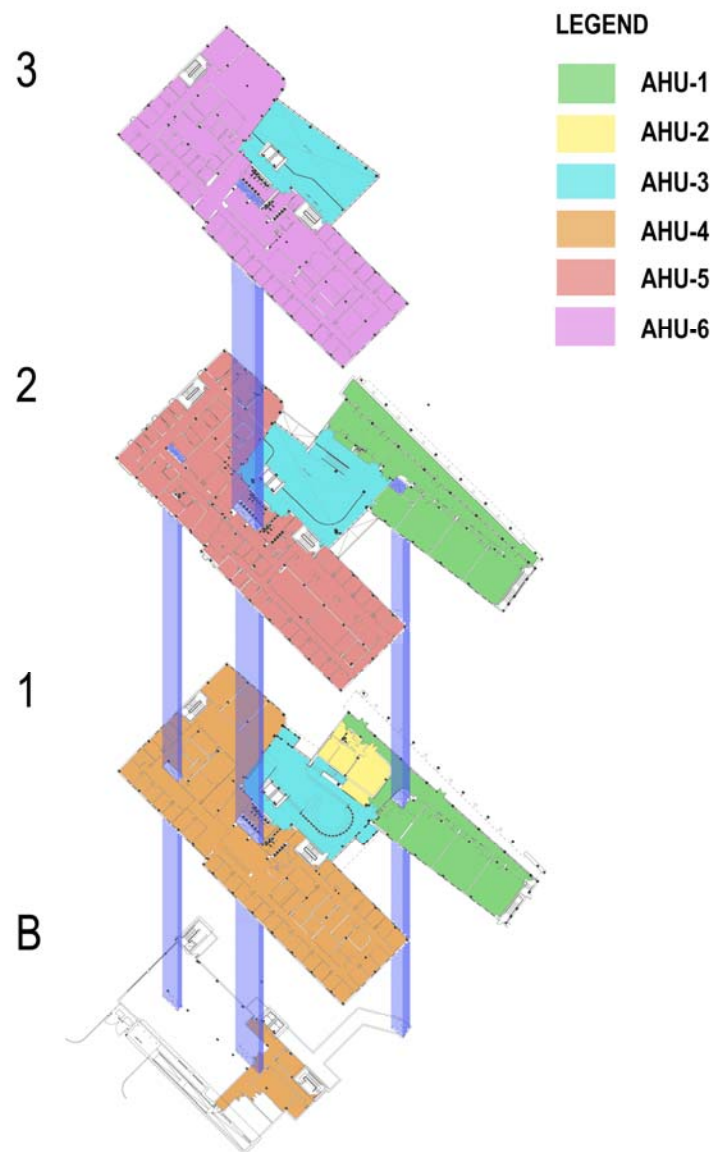

FIGURE 1: SLCC air handling unit service zones and shaft space.

## DESIGN CONDITIONS

The SLCC is located in the District of Columbia (Northeast). Outdoor air design conditions were obtained from the *ASHRAE Handbook of Fundamentals 2005* with data for Washington DC Reagan International Airport, which is approximately five (5) miles to the southwest of the facility. The 1% cooling and 99% heating conditions were selected.

Indoor conditions were based on standards for thermal comfort of occupants. Occupied spaces are to be maintained at 78°F in the winter and 72°F in the summer. Other spaces such as mechanical equipment spaces, janitors closets, etc. are not conditioned to the same degree as occupied spaces to reduce total thermal load. See Table 1 for a complete summary of design outdoor and room conditions.

Supply air is conditioned to 55°F and 50% relative humidity in the summer. In the winter some spaces with large heat losses are served with supply air heated to 60°F or 70°F. For example, this is applicable to the AHU serving the glass-curtain-wall-enclosed atrium. See Table 2 for a complete summary of supply air conditions for each AHU.

| zone →        | Design Conditions    |                        |                      |                      |                      |                      |
|---------------|----------------------|------------------------|----------------------|----------------------|----------------------|----------------------|
|               | Outdoor              |                        | AHU (all)            | CRAC                 | FCU (all)            | UH (all)             |
|               | T <sub>DB</sub> [°F] | T <sub>MCWB</sub> [°F] | T <sub>RA</sub> [°F] | T <sub>DB</sub> [°F] | T <sub>DB</sub> [°F] | T <sub>DB</sub> [°F] |
| Cooling (1%)  | 91.9                 | 75.3                   | 78                   | 72                   | 85                   | -                    |
| Heating (99%) | 20.2                 | -                      | 72                   | 72                   | 85                   | 55                   |

TABLE 1: Summary of design air conditions for different systems.

|                              | Supply Air Conditions |       |       |       |       |       |
|------------------------------|-----------------------|-------|-------|-------|-------|-------|
|                              | AHU-1                 | AHU-2 | AHU-3 | AHU-4 | AHU-5 | AHU-6 |
| T <sub>SA, Summer</sub> [°F] | 55                    | 55    | 55    | 55    | 55    | 55    |
| T <sub>SA, Winter</sub> [°F] | 60                    | 55    | 70    | 55    | 55    | 60    |

TABLE 2: Summary of supply air conditions for air handling units.

## AIR SIDE SYSTEM

The air side mechanical system of the SLCC is a traditional VAV system with reheat. A full schematic can be viewed in Figure 2. Outside air is introduced to the system through louvers at the basement level of the west façade (see Figure 9). This air is delivered to each of the six AHUs where it is mixed with return air. Full side economizer mode is employed in AHUs 1 and 4-6 when the outside air enthalpy is less than return air enthalpy. This is controlled by a single set of outdoor air temperature and humidity sensors and a set of return air temperature and humidity sensors for each AHU. Total outdoor air flow is determined by a flow measuring station. All of these inputs coordinate dampers and fans via a direct digital control (DDC) panel. All AHUs use hot water and chilled water coils to condition the air stream to the supply air temperatures shown in Table 3. The flow in these coils is regulated by valves controlled by the DDC panel and input return air temperature sensors. Each air handler also includes a pre-filter, supply fan, and primary filter. All of this information is detailed in Table 3 and the schematic in Figure 2.

Supply air is then distributed throughout the building through three shaft spaces (see Figure 1). VAV terminal units, most with hot water reheat or electric reheat, deliver the supply air to each zone via flexible ducted ceiling diffusers. Room temperature sensors feed data to the DDC panel which modulates the VAV airflow damper. If the room temperature is below the minimum temperature setpoint and the damper is at the minimum flow setting, the DDC modulates the VAV heating hot water valve or electric current to reheat the supply air. Return air is drawn into the plenum and transferred to the corridors via transfer ducts, and then drawn back to the AHU mixing boxes or exhausted by a return fan, also described in Table 4. Some spaces including toilet rooms, kitchens, and rooms with large format copiers have direct ducted exhaust to the outside. The exhaust fans for these spaces are modulated by the DDC when their associated piece of equipment or AHU is running. Sound attenuators on both the supply and return sides of the AHUs and supply sides of the VAV units minimize noise transmitted to occupied spaces from mechanical equipment. Transfer ducts are also sized to limit a direct path for sound propagation from the hallways to the spaces.

In addition to the general service equipment, three exhaust fans serve the atrium space in case of a fire emergency. Each is capable of removing 15,000 CFM of air from the atrium in order to meet fire codes.

| AIR HANDLING UNIT SCHEDULE (FAN) |          |         |                     |                       |                       |                     |      |            |       |     |               |
|----------------------------------|----------|---------|---------------------|-----------------------|-----------------------|---------------------|------|------------|-------|-----|---------------|
| TAG                              | LOCATION | FAN TAG | TOTAL AIRFLOW [CFM] | MINIMUM AIRFLOW [CFM] | MINIMUM OA FLOW [CFM] | TOTAL P. [IN. W.G.] | RPM  | DRIVE TYPE | MOTOR |     |               |
|                                  |          |         |                     |                       |                       |                     |      |            | BHP   | MHP | VOLTS / PHASE |
| AHU-1                            | B-200    | SF-1    | 17,800              | 8,500                 | 8,500                 | 5.0                 | 1800 | BELT       | 20.90 | 25  | 460 / 3       |
| AHU-2                            | B-200    | SF-2    | 2,600               | 2,600                 | 500                   | 4.6                 | 3600 | BELT       | 3.29  | 5   | 461 / 3       |
| AHU-3                            | B-200    | SF-3    | 13,800              | 13,800                | 3,100                 | 4.5                 | 1800 | BELT       | 14.07 | 15  | 462 / 3       |
| AHU-4                            | B-200    | SF-4    | 13,400              | 7,900                 | 6,500                 | 5.1                 | 1800 | BELT       | 15.32 | 20  | 463 / 3       |
| AHU-5                            | B-200    | SF-5    | 11,400              | 7,350                 | 5,700                 | 5.3                 | 1800 | BELT       | 13.50 | 15  | 464 / 3       |
| AHU-6                            | B-200    | SF-6    | 13,500              | 8,000                 | 6,600                 | 4.7                 | 1800 | BELT       | 14.42 | 15  | 465 / 3       |

TABLE 3: Schedule for air handling units.

| FAN SCHEDULE |                      |                      |                   |             |                    |                     |            |         |             |                |               |
|--------------|----------------------|----------------------|-------------------|-------------|--------------------|---------------------|------------|---------|-------------|----------------|---------------|
| TAG          | SERVICE              | LOCATION             | TYPE              | CFM AT 70°F | EXT. SP [IN. W.G.] | TOTAL SP [IN. W.G.] | DRIVE TYPE | FAN RPM | MOTOR       |                |               |
|              |                      |                      |                   |             |                    |                     |            |         | BHP (WATTS) | MIN HP (WATTS) | VOLTS / PHASE |
| SF-1         | AHU-1                | AHU-1                | AIRFOIL           | 17,800      | 1.6                | 5.0                 | BELT       | 1477    | 20.90       | 25             | 460 / 3       |
| SF-2         | AHU-2                | AHU-2                | AIRFOIL           | 2,600       | 2.4                | 5.4                 | BELT       | 2800    | 3.29        | 5              | 460 / 3       |
| SF-3         | AHU-3                | AHU-3                | AIRFOIL           | 13,800      | 4.2                | 4.5                 | BELT       | 1559    | 14.07       | 15             | 460 / 3       |
| SF-4         | AHU-4                | AHU-4                | AIRFOIL           | 13,400      | 1.5                | 5.1                 | BELT       | 1803    | 15.32       | 20             | 460 / 3       |
| SF-5         | AHU-5                | AHU-5                | AIRFOIL           | 11,400      | 2.0                | 5.2                 | BELT       | 1801    | 13.50       | 15             | 460 / 3       |
| SF-6         | AHU-6                | AHU-6                | AIRFOIL           | 13,500      | 1.5                | 4.7                 | BELT       | 1571    | 14.42       | 15             | 460 / 3       |
| SF-7         | MER                  | B200                 | PROP. SIDE WALL   | 3,000       | 0.2                | 0.2                 | BELT       | 703     | 0.23        | 1/4            | 115 / 1       |
| RF-1         | AHU-1                | B200                 | MIXED FL.         | 14950       | 1.6                | 1.6                 | BELT       | 1188    | 6.09        | 7.5            | 460 / 3       |
| RF-2         | NOT USED             |                      |                   |             |                    |                     |            |         |             |                |               |
| RF-3         | AHU-3                | B200                 | MIXED FL.         | 10700       | 1                  | 1                   | BELT       | 507     | 2.41        | 3              | 460 / 3       |
| RF-4         | AHU-4                | B200                 | MIXED FL.         | 10250       | 1.5                | 1.5                 | BELT       | 585     | 3.66        | 5              | 460 / 3       |
| RF-5         | AHU-5                | B200                 | MIXED FL.         | 8400        | 1.2                | 1.2                 | BELT       | 684     | 2.23        | 3              | 460 / 3       |
| RF-6         | AHU-6                | B200                 | MIXED FL.         | 10350       | 1.1                | 1.1                 | BELT       | 752     | 2.84        | 3              | 460 / 3       |
| EF-1         | ATRIUM SMOKE EXHAUST | THIRD FLOOR ROOF     | TUBE AXIAL INLINE | 15000       | 0.8                | 0.8                 | BELT       | 1384    | 6.13        | 7.5            | 460 / 3       |
| EF-2         | ATRIUM SMOKE EXHAUST | THIRD FLOOR ROOF     | TUBE AXIAL INLINE | 15000       | 0.8                | 0.8                 | BELT       | 1384    | 6.13        | 7.5            | 460 / 3       |
| EF-3         | ATRIUM SMOKE EXHAUST | THIRD FLOOR ROOF     | TUBE AXIAL INLINE | 15000       | 0.8                | 0.8                 | BELT       | 1384    | 6.13        | 7.5            | 460 / 3       |
| EF-4         | ATRUIM RELIEF        | THIRD FLOOR ROOF     | CENT. UTILITY     | 1500        | 0.4                | 0.4                 | BELT       | 754     | 0.18        | 1/4            | 115 / 1       |
| EF-5         | TOILET EXHAUST       | 2191                 | INLINE CABINET    | 75          | 0.4                | 0.4                 | DIRECT     | 687     | (129)       | (129)          | 115 / 1       |
| EF-6         | KITCHEN EXHAUST      | 2191                 | INLINE CABINET    | 100         | 0.4                | 0.4                 | DIRECT     | 774     | (129)       | (129)          | 115 / 1       |
| EF-7         | DRYER EXHAUST        | 2191                 | CENT. ROOF        | 150         | 0.3                | 0.3                 | DIRECT     | 2650    | (87)        | (87)           | 115 / 1       |
| EF-8         | MEDIA STUDIO         | SECOND FLOOR PORTICO | CENT. ROOF        | 150         | 0.4                | 0.4                 | BELT       | 1154    | 0.4         | 1/6            | 115 / 1       |
| EF-9         | FACULTY LOUNGE       | SECOND FLOOR PORTICO | CENT. ROOF        | 750         | 0.4                | 0.4                 | BELT       | 196     | 0.1         | 1/4            | 115 / 1       |
| EF-10        | TOILET EXHAUST       | THIRD FLOOR ROOF     | CENT. ROOF        | 2150        | 0.5                | 0.5                 | BELT       | 771     | 0.3         | 1/3            | 115 / 1       |
| EF-11        | TOILET EXHAUST       | THIRD FLOOR ROOF     | CENT. ROOF        | 1050        | 0.5                | 0.5                 | BELT       | 1171    | 0.16        | 1/4            | 115 / 1       |
| EF-12        | WORK ROOM            | THIRD FLOOR ROOF     | CENT. ROOF        | 400         | 0.5                | 0.5                 | BELT       | 1244    | 0.07        | 1/6            | 115 / 1       |
| EF-13        | WORK ROOM            | THIRD FLOOR ROOF     | CENT. ROOF        | 100         | 0.5                | 0.5                 | BELT       | 1119    | 0.03        | 1/6            | 115 / 1       |
| EF-14        | ELEC. ROOM           | B275                 | CENT. INLINE      | 1800        | 0.5                | 0.5                 | BELT       | 1182    | 0.35        | 1/3            | 115 / 1       |
| EF-15        | FIRE PUMP ROOM       | B275                 | CENT. INLINE      | 400         | 0.5                | 0.5                 | BELT       | 1450    | 0.13        | 1/4            | 115 / 1       |
| EF-16        | MER                  | B200                 | CENT. INLINE      | 3000        | 0.5                | 0.5                 | BELT       | 872     | 0.48        | 1/2            | 115 / 1       |

TABLE 4: Schedule for fans.



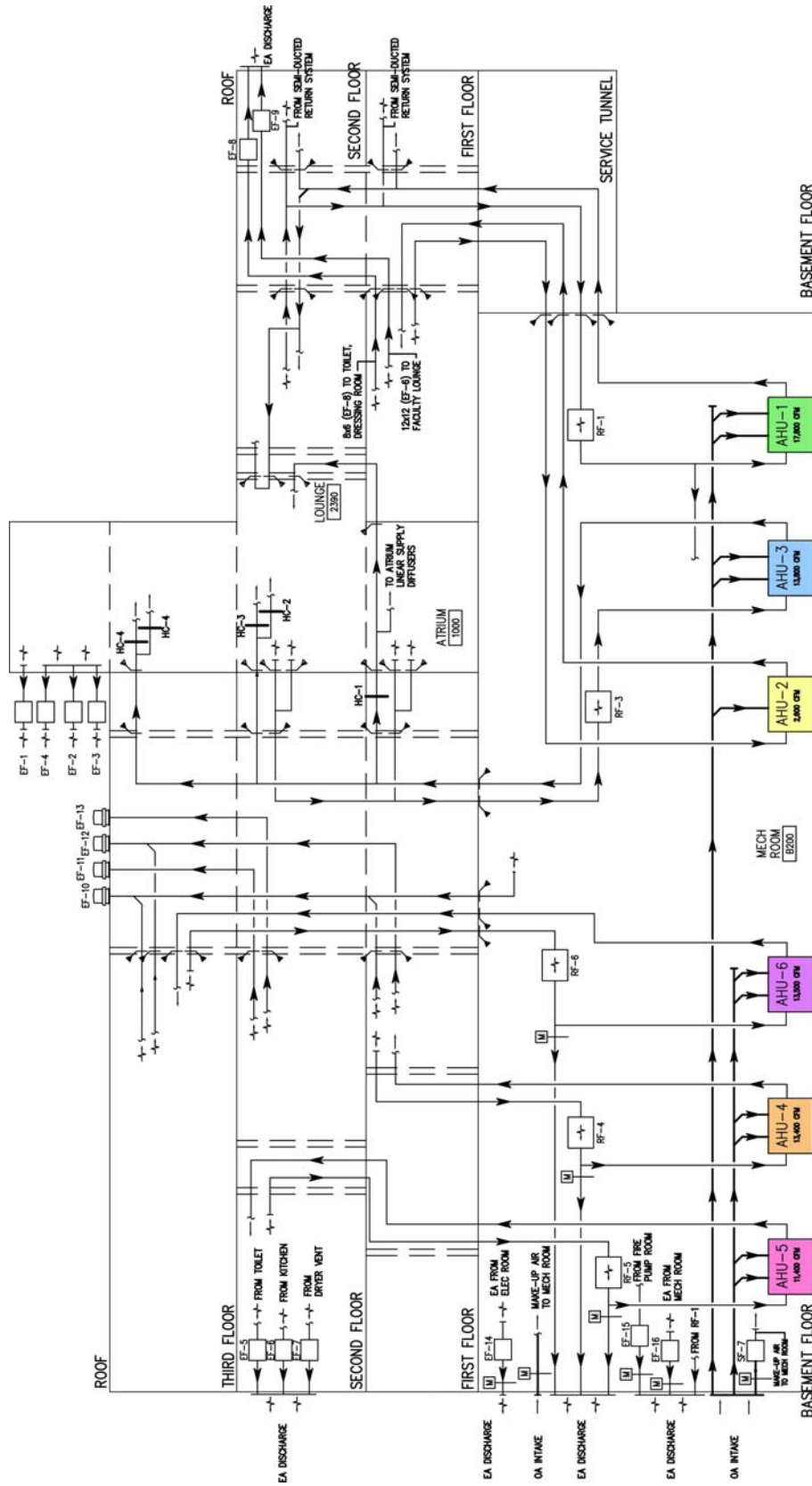

AIR SYSTEM SCHEMATIC

FIGURE 2: Air System Schematic for the SLCC.

## WATER SIDE SYSTEM (CHILLED WATER)

The Central Utilities Building at Gallaudet University serves the SLCC with chilled water at 43°F. These service lines enter and leave the facility under the east entrance and are directed to/from the mechanical equipment room (MER). Most of the mechanical piping is confined to the MER and return follows parallel to the service lines back to the Central Utilities Building. The organization of this system can be viewed in the Chilled Water Schematics (see Figure 3).

The chilled water supply directly serves the loads in the SLCC. After passing through an air separator and expansion tank (see table 5) the chilled water is directed to two parallel 730 gpm pumps (one standby) each capable of producing 93 ft.w.g. of head (see Table 6). These pumps are enabled either manually or automatically by the DDC panel when a cooling coil needs to be used. The pumps are modulated by variable frequency drives controlled by input from a pressure differential sensor between the supply and return flows to the adjustable frequency motor controllers (AFMC). The vast majority of chilled water directly serves the cooling coils in the AHUs (see Table 7). Less than four percent of the total flow is directed to the eight fan coil units (FCU) and computer room air conditioning (CRAC) unit. Return chilled water is directly sent back to the Central Utilities Building.

| EXPANSION TANK AND AIR SEPARATOR SYSTEM SCHEDULE |         |          |           |                     |                   |          |                     |               |     |                   |
|--|---------|----------|-----------|---------------------|-------------------|----------|---------------------|---------------|-----|-------------------|
| TAG  | SERVICE | LOCATION | TYPE      | SYSTEM VOLUME [gal] | SYSTEM TEMP RANGE |          |                     | AIR SEPARATOR |     |                   |
|  |         |          |           |                     | MIN [°F]          | MAX [°F] | MIN TANK SIZE [gal] | TAG           | GPM | MAX PD [FT. W.G.] |
| ET-1   | CHW     | B200     | DIAPHRAGM | 2600                | 42                | 100      | 128                 | AS-1          | 730 | 1.0               |
| ET-2   | HHW     | B200     | DIAPHRAGM | 650                 | 42                | 160      | 156                 | AS-2          | 280 | 1.0               |

TABLE 5: Schedule for Expansion Tank.

| PUMP SCHEDULE |               |          |                          |       |           |     |                       |               |         |     |      |               |
|---------------|---------------|----------|--------------------------|-------|-----------|-----|-----------------------|---------------|---------|-----|------|---------------|
| TAG           | SERVICE       | LOCATION | TYPE                     | FLUID | TEMP [°F] | GPM | TOTAL HEAD [IN. W.G.] | MIN. EFF. [%] | MOTOR   |     |      |               |
|               |               |          |                          |       |           |     |                       |               | MAX BHP | HP  | RPM  | VOLTS / PHASE |
| P-1           | CHW           | B200     | SINGLE STAGE CENTRIFUGAL | WATER | 43        | 730 | 93                    | 79            | 21      | 25  | 1800 | 460 / 3       |
| P-2           | CHW (STANDBY) | B200     | SINGLE STAGE CENTRIFUGAL | WATER | 43        | 730 | 93                    | 79            | 21      | 25  | 1800 | 460 / 3       |
| P-3           | HHW           | B200     | SINGLE STAGE CENTRIFUGAL | WATER | 180       | 280 | 68                    | 75            | 6       | 7.5 | 1800 | 460 / 3       |
| P-4           | HHW (STANDBY) | B200     | SINGLE STAGE CENTRIFUGAL | WATER | 180       | 280 | 68                    | 75            | 6       | 7.5 | 1800 | 460 / 3       |
| P-5           | AHU-1 PH      | B200     | INLINE                   | WATER | 180       | 56  | 28                    | 41            | 0.44    | 1/2 | 1800 | 460 / 3       |
| P-6           | AHU-2 PH      |          |                          |       |           |     |                       |               |         |     |      |               |
| P-7           | AHU-3 PH      | B200     | INLINE                   | WATER | 180       | 60  | 28                    | 41            | 0.45    | 1/2 | 1800 | 460 / 3       |
| P-8           | AHU-4 PH      | B200     | INLINE                   | WATER | 180       | 37  | 28                    | 38            | 0.31    | 1/2 | 1800 | 460 / 3       |
| P-9           | AHU-5 PH      | B200     | INLINE                   | WATER | 180       | 32  | 28                    | 36            | 0.29    | 1/2 | 1800 | 460 / 3       |
| P-10          | AHU-6 PH      | B200     | INLINE                   | WATER | 180       | 42  | 28                    | 39            | 0.35    | 1/2 | 1800 | 460 / 3       |

TABLE 6: Schedule for SLCC pumps.

| AIR HANDLING UNIT SCHEDULE (COIL) |          |           |           |              |                      |                      |                      |                      |                      |                       |            |                   |                    |                              |
|-----------------------------------|----------|-----------|-----------|--------------|----------------------|----------------------|----------------------|----------------------|----------------------|-----------------------|------------|-------------------|--------------------|------------------------------|
| TAG                               | LOCATION | COIL TYPE | TOTAL MBH | SENSIBLE MBH | AIR                  |                      |                      |                      | WATER                |                       |            | MAX PD [IN. W.G.] | PRI/SEC FILTER EFF | MAX COIL FACE VELOCITY [FPM] |
|                                   |          |           |           |              | ENTERING             |                      | LEAVING              |                      | T <sub>IN</sub> [°F] | T <sub>OUT</sub> [°F] | FLOW [GPM] |                   |                    |                              |
|                                   |          |           |           |              | T <sub>DB</sub> [°F] | T <sub>WB</sub> [°F] | T <sub>DB</sub> [°F] | T <sub>WB</sub> [°F] |                      |                       |            |                   |                    |                              |
| AHU-1                             | B-200    | PREHEAT   | 550       | -            | 0.7                  | -                    | 60.0                 | -                    | 180                  | 160                   | 56         | 1.0               | 25-30/85           | 500                          |
|                                   |          | COOLING   | 839       | 593          | 84.5                 | 68.7                 | 53.7                 | 53.6                 | 43                   | 53                    | 168        | 1.0               |                    |                              |
| AHU-2                             | B-200    | PREHEAT   | -         | -            | -                    | -                    | -                    | -                    | -                    | -                     | -          | 1.0               | 25-30/85           | 500                          |
|                                   |          | COOLING   | 97        | 77           | 81.2                 | 65.9                 | 53.7                 | 53.6                 | 43                   | 53                    | 20         | 1.0               |                    |                              |
| AHU-3                             | B-200    | PREHEAT   | 596       | -            | 0.0                  | -                    | 40.0                 | -                    | 180                  | 160                   | 60         | 1.0               | 25-30/85           | 500                          |
|                                   |          | COOLING   | 511       | 406          | 81.0                 | 65.9                 | 53.7                 | 53.6                 | 43                   | 53                    | 103        | 1.0               |                    |                              |
| AHU-4                             | B-200    | PREHEAT   | 362       | -            | 13.0                 | -                    | 55.0                 | -                    | 180                  | 160                   | 37         | 1.0               | 25-30/85           | 500                          |
|                                   |          | COOLING   | 670       | 458          | 85.3                 | 69.5                 | 53.7                 | 53.6                 | 53                   | 53                    | 134        | 1.0               |                    |                              |
| AHU-5                             | B-200    | PREHEAT   | 310       | -            | 15.4                 | -                    | 55.0                 | -                    | 180                  | 160                   | 32         | 1.0               | 25-30/85           | 500                          |
|                                   |          | COOLING   | 605       | 387          | 85.2                 | 69.8                 | 53.7                 | 52.9                 | 43                   | 53                    | 121        | 1.0               |                    |                              |
| AHU-6                             | B-200    | PREHEAT   | 418       | -            | 11.7                 | -                    | 60.0                 | -                    | 180                  | 160                   | 42         | 1.0               | 25-30/85           | 500                          |
|                                   |          | COOLING   | 706       | 479          | 86.5                 | 70.1                 | 53.7                 | 53.6                 | 43                   | 53                    | 142        | 1.0               |                    |                              |

TABLE 7: Schedule for AHU coils.

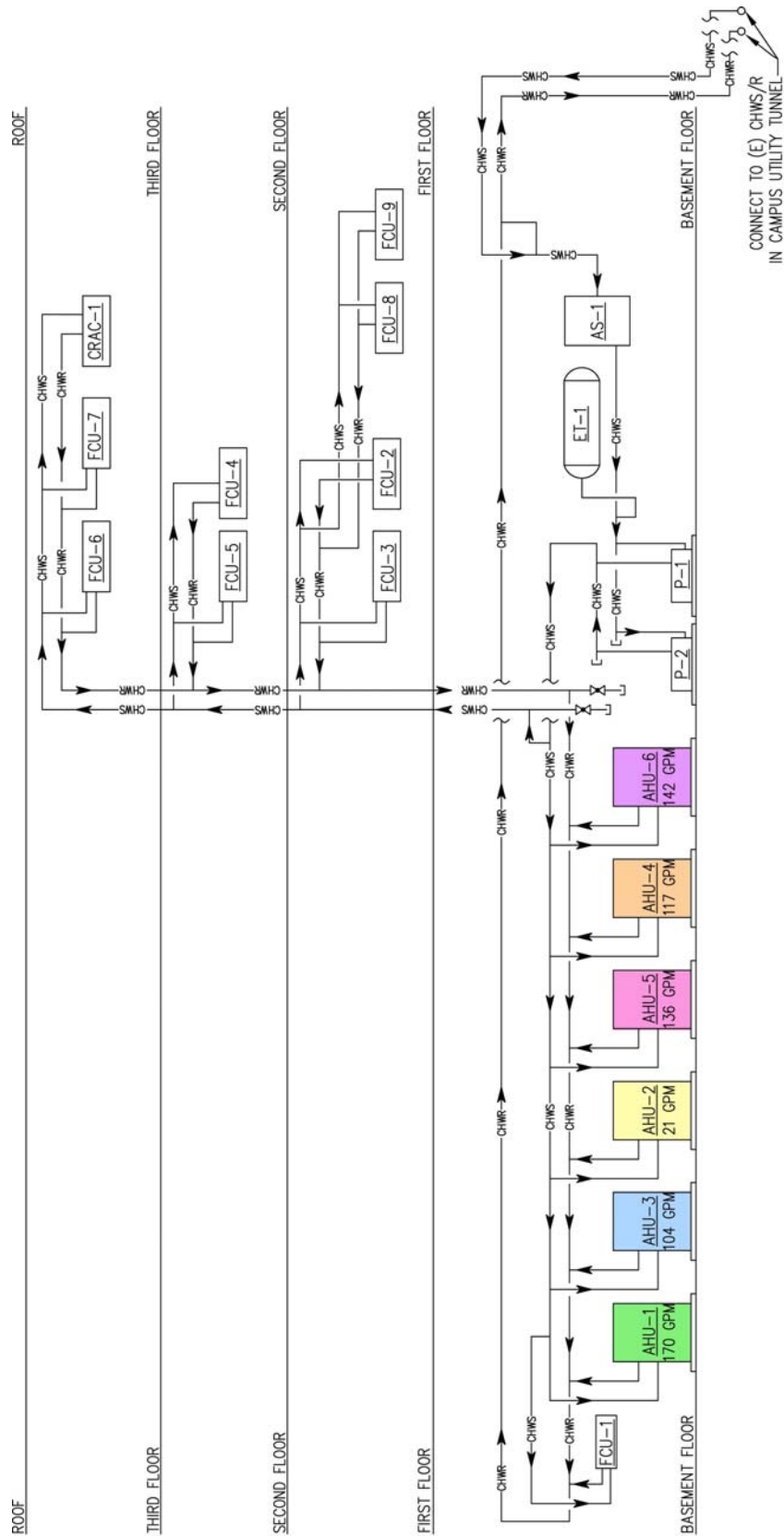

CHILLED WATER DIAGRAM

FIGURE 3: Air System Schematic for the SLCC

## WATER SIDE SYSTEM (HEATING HOT WATER)

The heating hot water (HHW) system of the SLCC is served by high pressure steam (HPS) at 100 psig from the Central Utilities Building on the Gallaudet Campus. The energy of the steam is transferred to a closed heating hot water loop within the SLCC via a pressure reducing (PRV) station and heat exchanger. The organization of these systems can be viewed in the Heating Hot Water Schematics 1 and 2 (Figures 4 and 5).

The steam supplied to the SLCC also enters and leaves the facility under the east entrance. HPS is directed to a pressure reducing station in the MER where the pressure is reduced from 100 psig to 15 psig. This PRV Station has a capacity of 2800 lbs/hr and two valves controlling 1/3 and 2/3 of the flow (see Table 8). The low pressure steam (LPS) is then directed to both the steam-to-water heat exchanger and the domestic hot water heater. These devices transfer thermal energy from the steam to the water in the system (see Table 9).

The domestic hot water heater uses an indirect steam-to-hot-water heat exchanger and has an auxiliary electric heater for when steam service is down for maintenance. Water stored in the tank is maintained at 140°F. When the domestic hot water pump (see Table 6) is enabled to run a temperature sensor on the return flow is activated. If this sensor measures a minimum temperature of 95°F it activates a recirculating pump until the maximum temperature of 110°F is reached. The recirculating pump is also on a time schedule to maintain quick domestic hot water service.

The majority of the LPS is directed to the heating hot water plate and frame heat exchanger. This heat exchanger has a capacity of 2800 MBH and serves the hot water coils in all AHUs, VAV HW reheat coils, HW UHs, and the CRAC unit. One of two 280 gpm pumps (one standby) are activated whenever a heating coil is in use and controlled with AFMCs. Much like the chilled water system, a differential pressure sensor between the supply and return flows feeds data to the AFMCs. Return HHW is directed to an air separator and expansion tank because the pressure on the water is lower here. Return water is then reheated in the heat exchanger and recirculated throughout the system. Condensate from the steam side of the system is collected and pumped back to the Central Utilities Building via a condensate receiver and pump (see Table 10).

| STEAM PRV STATION SCHEDULE |         |          |          |                      |                 |        |        |         |
|----------------------------|---------|----------|----------|----------------------|-----------------|--------|--------|---------|
| TAG                        | SERVICE | LOCATION | TYPE     | CAPACITY<br>[lbs/hr] | STEAM           |        | VALVES |         |
|                            |         |          |          |                      | PRESSURE [psig] |        | NO.    | % FLOW  |
|                            |         |          |          |                      | INLET           | OUTLET |        |         |
| PRV-1                      | SLCC    | B200     | PARALLEL | 2800                 | 100             | 15     | 2      | 33 / 67 |

TABLE 8: Schedule for Pressure Reducing Station.

| HEAT EXCHANGER SCHEDULE |         |          |                  |                   |                    |                  |       |                      |                       |                     |
|-------------------------|---------|----------|------------------|-------------------|--------------------|------------------|-------|----------------------|-----------------------|---------------------|
| TAG                     | SERVICE | LOCATION | TYPE             | CAPACITY<br>[MBH] | STEAM              |                  | WATER |                      |                       |                     |
|                         |         |          |                  |                   | PRESSURE<br>[psig] | FLOW<br>[lbs/hr] | GPM   | T <sub>IN</sub> [°F] | T <sub>OUT</sub> [°F] | MAX PD<br>[FT. W.G] |
| HX-1                    | SLCC    | B200     | PLATE &<br>FRAME | 2800              | 15                 | 2800             | 280   | 160                  | 180                   | 6.8                 |

TABLE 9: Schedule for Steam-HHW Heat Exchanger.

| CONDENSATE RECEIVER AND PUMP SCHEDULE |          |          |         |                             |                            |              |                          |                               |
|---------------------------------------|----------|----------|---------|-----------------------------|----------------------------|--------------|--------------------------|-------------------------------|
| TAG                                   | SERVICE  | LOCATION | TYPE    | STEAM<br>PRESSURE<br>[psig] | COND.<br>LOAD<br>[lbs./hr] | NO.<br>PUMPS | DISCH.<br>HEAD<br>[psig] | RECEIVER<br>CAPACITY<br>[gpm] |
| PPCP-1                                | STM/COND | B200     | SIMPLEX | 100                         | 4000                       | 1            | 25                       | 31                            |

TABLE 10: Schedule for Condensate Receiver.

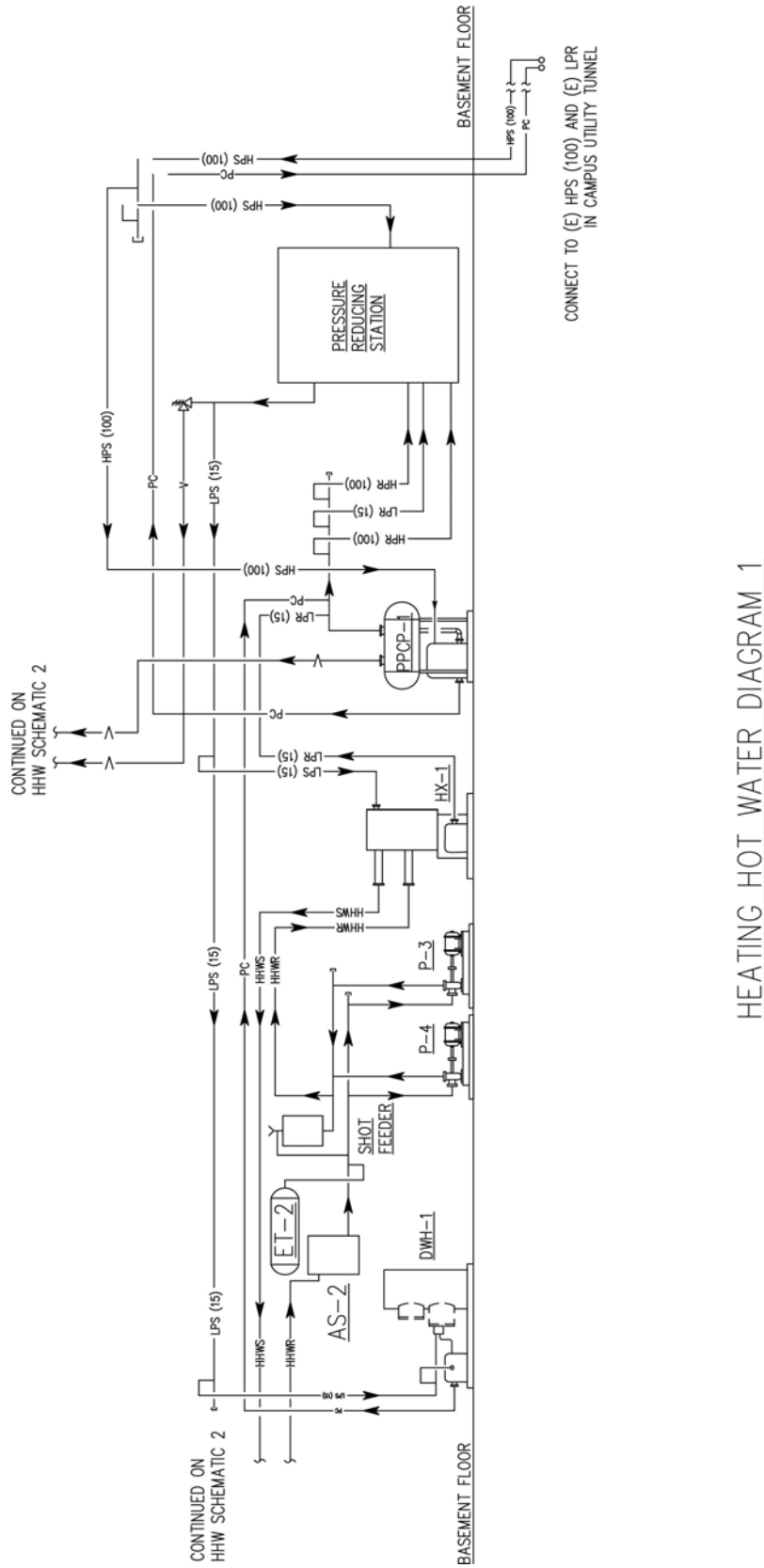
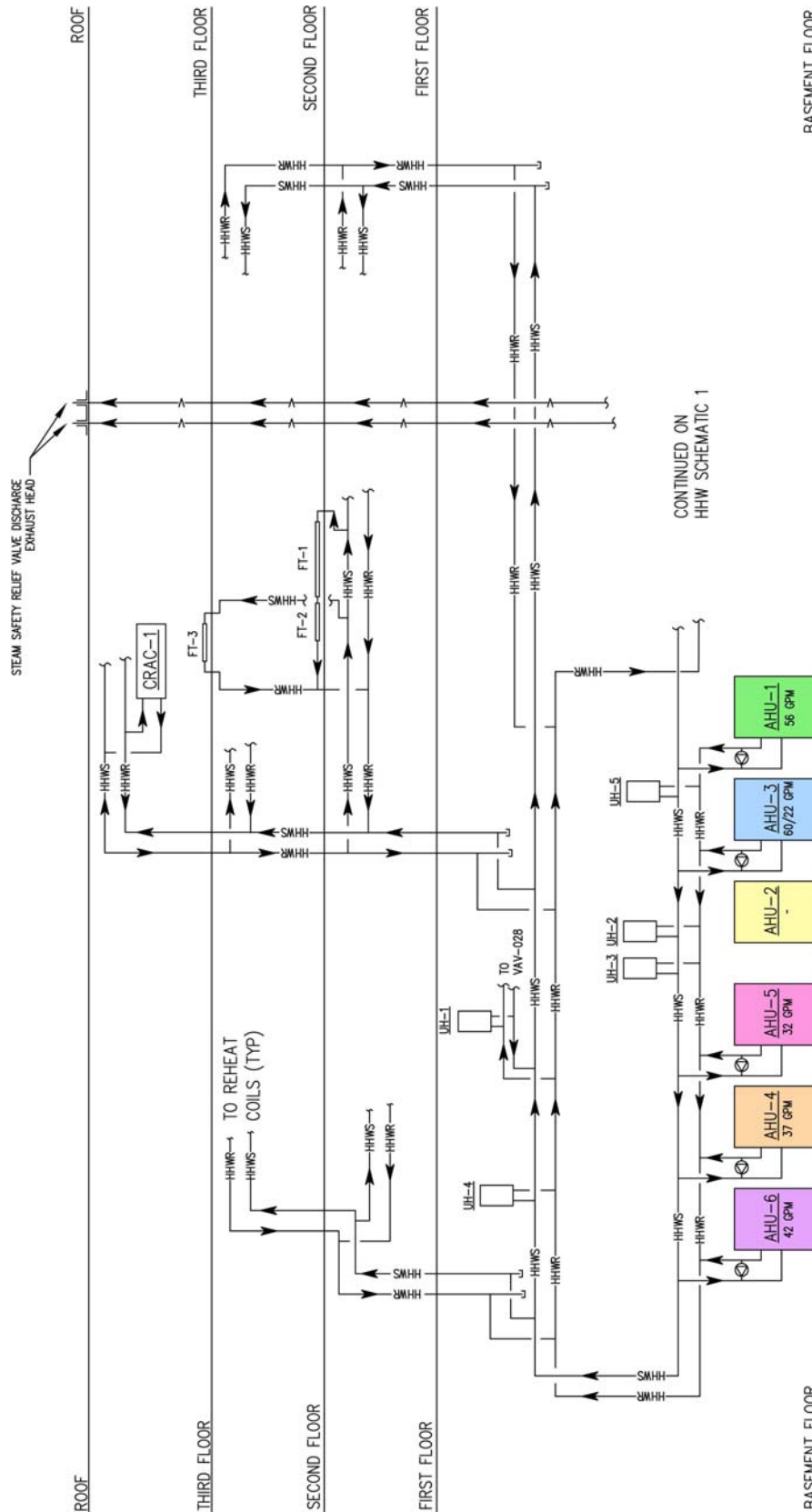

FIGURE 4: Heating Hot Water System Schematic 1 for the SLCC

HEATING HOT WATER DIAGRAM 1



HEATING HOT WATER DIAGRAM 2

FIGURE 5: Heating Hot Water System Schematic 2 for the SLCC (load side).

## ASHRAE STANDARDS COMPLIANCE

### ASHRAE Std. 62.1 - 2004 PERFORMANCE

The calculations in *Technical Report One: ASHRAE Std. 62.1 Ventilation Compliance* find that five of the six AHUs serving the SLCC do not meet the minimum requirements from ASHRAE Std. 62.1-2004. AHU – 1 provides approximately 24% excess outdoor air to the spaces it serves. Overall, however, the designed HVAC system provides more than 30% less outdoor air than is necessary per Std. 62.1. Specific findings may be reviewed in Table 11.

The design of the SLCC HVAC system was based on a standard CFM/Occupant airflow rate (occupancy density) in ASHRAE Std. 62.1-1999, with standards for water closets and support spaces based on rules of thumb. The calculations in this report, however, followed the prescriptive Ventilation Rate Procedure and included both occupancy and floor area airflow rate coefficients.

This discrepancy is predominantly due to the system ventilation efficiency. Critical spaces force the design outdoor air intake rate to be overcompensated. An individual space that requires a high outdoor air fraction governs all other spaces. The minimum requirements from Std. 62.1 must be met at all times for this space, thus forcing the design to condition a proportionally larger amount of outdoor air for the entire system.

In order to complete these calculations, certain assumptions were made that had notable impacts on this system ventilation efficiency calculation. Among them was the correlation between the functions of the individual spaces and those described in the standard. Also, design minimum supply air rates were assumed to be equivalent to the system primary airflow. In cases where the minimum calculated outdoor airflow rate exceeded the minimum supply airflow, the primary outdoor air fraction was assumed to be 1.0. These assumptions are the source of the greatest differential between design and calculated airflows.

| SUMMARY       |                |                  |                 |                 |                |            |                       |                         |                    |
|---------------|----------------|------------------|-----------------|-----------------|----------------|------------|-----------------------|-------------------------|--------------------|
| AHU           | # Zones / VAVs | Area Served [SF] | Design OA [CFM] | Design SA [CFM] | Capacity [CFM] | Unit Size* | V <sub>ot</sub> [CFM] | % Below V <sub>ot</sub> | Max Z <sub>p</sub> |
| 1             | 19             | 13185            | 4130            | 17400           | 17700          | 40         | 3320                  | 24.4                    | 0.55               |
| 2             | 3              | 1311             | 360             | 2230            | 2500           | 6          | 470                   | -23.4                   | 0.15               |
| 3             | 0              | 7990             | 2890            | 13070           | 13800          | 35         | 3550                  | -18.6                   | 0.32               |
| 4             | 44             | 15285            | 4650            | 14080           | 13300          | 30         | 7485                  | -37.9                   | 1.00               |
| 5             | 37             | 15061            | 4550            | 11965           | 11200          | 30         | 6785                  | -32.9                   | 1.00               |
| 6             | 39             | 15146            | 5050            | 14130           | 13400          | 30         | 9550                  | -47.1                   | 1.00               |
| <b>TOTALS</b> | <b>142</b>     | <b>67978</b>     | <b>21630</b>    | <b>72875</b>    | <b>71900</b>   |            | <b>31160</b>          | <b>-30.6</b>            |                    |

\* Unit Size for TRANE M-Series Climate Changer AHU

TABLE 11: Summary of OA ventilation calculations from *Technical Report One*.

## ASHRAE Std. 90.1-2004 PERFORMANCE

ASHRAE Standard 90.1 is written through a partnership with the Illuminating Engineers Society of North America (IESNA) in order to integrate the mechanical and electrical design disciplines. The goal is to coordinate their standards to optimize energy performance and occupant comfort. One of the major changes in the 2004 version of this standard is the reduction of allowable lighting power densities (LPD) from previous versions.

The SLCC, however, was designed versus the 1999 version of ASHRAE Standard 90.1 in order to comply with LEED-NC V2.1. Therefore many spaces within the SLCC do not meet the space-by-space allowable LPD per ASHRAE 90.1-2004. Table 12 illustrates the overall space-by-space averages for each AHU. A full report of each space and its compliance can be viewed in the second technical report. It should be noted, however, that the SLCC meets criteria for the building area method LPD calculation in ASHRAE 90.1-2004 (see Table 13).

Additionally, the SLCC meets the ASHRAE 90.1-2004 requirement for occupancy sensors for space lighting control.

**Space-by-Space Method:**

| System                    | Area [SF]    | Design                                    |                           | ASHRAE Std. 90.1                             |                              | Meets 90.1 Requirements |
|---------------------------|--------------|---|---------------------------|--|------------------------------|-------------------------|
|                           |              | Actual Area Weighted Power Density [W/SF] | Actual Lighting Power [W] | Allowable Area Weighted Power Density [W/SF] | Allowable Lighting Power [W] |                         |
| AHU-1                     | 13185        | 1.23                                      | 16203                     | 1.03   | 13546                        | NO                      |
| AHU-2                     | 1311         | 0.91                                      | 1188                      | 0.51   | 667                          | NO                      |
| AHU-3                     | 7990         | 1.08                                      | 8652                      | 0.65   | 5210                         | NO                      |
| AHU-4                     | 15285        | 0.89                                      | 13536                     | 1.03   | 15778                        | YES                     |
| AHU-5                     | 15061        | 0.94                                      | 14230                     | 0.97   | 14684                        | YES                     |
| AHU-6                     | 15146        | 1.00                                      | 15199                     | 1.09   | 16522                        | YES                     |
| <b>Total:</b>             | <b>67978</b> | <b>6.05</b>                               | <b>69008</b>              | <b>5.29</b>                                  | <b>66406</b>                 | <b>NO</b>               |
| <b>Area Weighted Avg:</b> |              | <b>1.02</b>                               |                           | <b>0.98</b>                                  |                              | <b>NO</b>               |

Design-to-Std. Ratio: 103.9%

TABLE 12: Space-by-space method calculation for LPD compliance with ASHRAE 90.1-2004.

**Building Area Method:**

(Assume "School/University" Building Type)

| System | Area [SF] | Design                                    |                           | ASHRAE Std. 90.1                             |                              | Meets 90.1 Requirements |
|--------|-----------|---|---------------------------|--|------------------------------|-------------------------|
|        |           | Actual Area Weighted Power Density [W/SF] | Actual Lighting Power [W] | Allowable Area Weighted Power Density [W/SF] | Allowable Lighting Power [W] |                         |
| 1-6    | 67978     | 1.02                                      | 69008                     | 1.20   | 81574                        | YES                     |

TABLE 13: Building area method calculation for LPD compliance with ASHRAE 90.1-2004.



## BUILDING ENVELOPE PERFORMANCE

The walls, fenestration, and roofs that comprise the building envelope have a major impact on the energy use of a building. Heat transfer through a wall, solar radiation gain, and infiltration are the primary forms of thermal energy transfer through the envelope that the mechanical system must compensate for. Section 5 of ASHRAE Standard 90.1-2004 addresses these thermal loads and sets criteria that each component of the envelope must meet. Furthermore, LEED-NC V2.2 offers Sustainable Sites Credit 7.1 to minimize heat island effects by utilizing a highly reflective roof. This minimizes both local outdoor heat islands and the thermal load gain within the building.

The design of the Sorenson Language and Communication Center addresses these standards by minimizing glazing area exposed to sunlight, using a highly reflective coating on the roof, and employing thermally efficient wall constructions. First, the total vertical glazing area is 13,740 SF, or approximately 35.5% of the total wall area. This design already meets the ASHRAE 90.1 maximum of 50% glazed wall area, but goes further by orienting approximately 52% of that glazing area north (see Table 14, Figures 6-9). This minimizes solar radiation gain inside the building. Also, all doors to the exterior either open from non-conditioned spaces or have vestibules. Next, the roofs of the SLCC are covered with an Energy Star compliant, high reflectance, high emmissivity roofing membrane. This light colored material reflects much more solar radiation than traditional roofing membranes while performing traditional bulk water management. As a result, the building absorbs much less solar energy and emits less thermal radiation to the surroundings. Finally, walls are constructed to have a total u-value that meets or exceeds ASHRAE 90.1 maximums for the climate in Washington, DC (see Table 15). The SLCC is enclosed with three four typical wall constructions: a brick cavity wall, a zinc sided barrier wall, and a glass and aluminum curtain wall. The curtain wall is assumed to be constructed with insulating glazing units (IGUs) with the same u-value as typical windows in the SLCC.

In addition to these design elements, the envelope of the SLCC is specified to be sealed in accordance with ASHRAE Standard 90.1 Section 5.4.3.1.

An analysis of the glazing area and wall thermal efficiencies can be found below.

| Glazing-to-Wall Area Ratio |                      |                         |                               |                             |
|----------------------------|----------------------|-------------------------|-------------------------------|-----------------------------|
| Wall Type                  | Total Wall Area [SF] | Total Glazing Area [SF] | Glazing Area Facing North[SF] | Percent Glazed Total Façade |
| Masonry Façade             | 22804.0              |                         |                               | 11.3%                       |
| Glazing in Masonry         |                      | 2582.0                  |                               |                             |
| Zinc Sided Façade          | 4318.0               |                         | 594                           | 13.6%                       |
| Glazing in Zinc Sided      |                      | 588.0                   |                               |                             |
| Curtain Wall Façade        | 10838.0              |                         | 6396                          | 95.0%                       |
| Curtain Wall Glazing       |                      | 10300.0                 |                               |                             |
| <b>Total</b>               | <b>37960</b>         | <b>13470</b>            | <b>6990</b>                   | <b>35.5%</b>                |

TABLE 14: Analysis of glazing area-to-total wall area ratio.

| Envelope Construction U-Values |                      |                             |         |         | ASHRAE 90.1-2004 |                         |
|--------------------------------|----------------------|-----------------------------|---------|---------|------------------|-------------------------|
| Wall Type                      | Total Wall Area [SF] | Percent Total Envelope Area | R-Value | U-Value | Maximum U-Value  | Meets ASHRAE 90.1-2004? |
| Roof                           | 33624.0              | 47.0%                       | 17.17   | 0.058   | 0.063            | YES                     |
| Masonry Façade                 | 22804.0              | 31.9%                       | 22.25   | 0.045   | 0.124            | YES                     |
| Zinc Sided Façade              | 4318.0               | 6.0%                        | 21.01   | 0.05    | 0.124            | YES                     |
| Curtain Wall/Glazing           | 10838.0              | 15.1%                       | 2.89    | 0.35    | 0.570            | YES                     |

TABLE 15: Analysis of envelope construction.



FIGURE 6: North Elevation of SLCC.



FIGURE 7: South Elevation of SLCC.



FIGURE 8: East Elevation of SLCC.



FIGURE 9: West Elevation of SLCC.

## LEED RATING COMPLIANCE

### LEED-NC V2.1 COMPLIANCE

From the beginning of the design process SmithGroup architects and engineers worked towards the ultimate goal of designing a unique and world-class facility for Gallaudet University that would achieve U.S. Green Building Council LEED Certification. Several prerequisites for the design needed to be met to achieve this certification, including meeting ASHRAE Standard 90.1 requirements. Because the design process started in early 2005 the SLCC is designed to meet LEED-NC V2.1 requirements. According to the LEED-NC V2.1 Scorecard completed towards the end of the contract documents phase, a total of twenty-six (26) points are expected to be earned with a potential for six (6) more. This would likely garner a LEED Certified Rating (27-32 points), or at best a LEED Silver Rating (33-38 points).

Design elements of the SLCC intended to gain LEED points include reducing the heat island effect, a water use reduction of over 30%, and selective material use and construction. For example, a highly reflective roofing membrane and minimal building footprint reduce the solar energy absorption and thermal mass of the building. In order to gain four water efficiency credits, storm water will be captured to irrigate water efficient landscaping, while waterless urinals, dual-flush toilets, and faucet automatic sensors reduce sanitary water use. Recycled materials and locally produced products will be used for construction and finishes.

With regard to the mechanical system, all Energy and Atmosphere Prerequisites are expected to be met. Beyond that, a possible two (2) of ten (10) points for optimal energy performance could be earned. This leaves at least eight (8) points available to secure a higher LEED rating. Since no refrigerants will be used in this building and the campus chiller plant uses CFC-free HFC-134A as a refrigerant, EA Credit 4 would be earned for minimizing ozone depletion. Additional commissioning would garner one (1) more EA point. Indoor air quality would be optimized with the installation of low-emitting adhesives, paints, carpets, and woods and a construction IAQ management plan, thus gaining another six (6) points. Housekeeping and copy rooms would be exhausted to provide indoor chemical and pollutant source control, thus gaining another point.

### LEED-NC V2.2 COMPLIANCE

An analysis of the SLCC design versus LEED-NC V2.2 was conducted for this report based on the V2.1 analysis provided by the architects. If a design element met both V2.1 and V2.2 criteria, it was assumed to gain its respective point. Some slight differences in the credit content actually provided an additional LEED point with V2.2. The SLCC would likely gain the Sustainable Sites Credit 2: Development Density & Community Connectivity for its location in the urban core of the District of Columbia and the services it can provide the community. Any points gained from EA Credit 1: Optimize Energy Performance are determined from the building energy model in this report.

See Table 16 for the LEED-NC V2.2 checklist for likely points earned by the SLCC. A total of twenty-eight (28) points are expected, with a possibility for six (6) more, thus earning a LEED Certified Rating.



LEED-NC

LEED-NC Version 2.2 Registered Project Checklist

Gallaudet University SLCC  
Washington, DC

Yes ? No

**8** **1** **5** **Sustainable Sites** **14 Points**

|          |          |          |            |   |          |
|----------|----------|----------|------------|---|----------|
| <b>Y</b> |          |          | Prereq 1   | <b>Construction Activity Pollution Prevention</b>                           | Required |
| <b>1</b> |          |          | Credit 1   | <b>Site Selection</b>   | 1        |
| <b>1</b> |          |          | Credit 2   | <b>Development Density &amp; Community Connectivity</b>                     | 1        |
|          |          | <b>1</b> | Credit 3   | <b>Brownfield Redevelopment</b>   | 1        |
| <b>1</b> |          |          | Credit 4.1 | <b>Alternative Transportation, Public Transportation Access</b>             | 1        |
| <b>1</b> |          |          | Credit 4.2 | <b>Alternative Transportation, Bicycle Storage &amp; Changing Rooms</b>     | 1        |
|          |          | <b>1</b> | Credit 4.3 | <b>Alternative Transportation, Low-Emitting and Fuel-Efficient Vehicles</b> | 1        |
|          | <b>1</b> |          | Credit 4.4 | <b>Alternative Transportation, Parking Capacity</b>                         | 1        |
|          |          | <b>1</b> | Credit 5.1 | <b>Site Development, Protect or Restore Habitat</b>                         | 1        |
| <b>1</b> |          |          | Credit 5.2 | <b>Site Development, Maximize Open Space</b>                                | 1        |
|          |          | <b>1</b> | Credit 6.1 | <b>Stormwater Design, Quantity Control</b>                                  | 1        |
| <b>1</b> |          |          | Credit 6.2 | <b>Stormwater Design, Quality Control</b>                                   | 1        |
| <b>1</b> |          |          | Credit 7.1 | <b>Heat Island Effect, Non-Roof</b>   | 1        |
| <b>1</b> |          |          | Credit 7.2 | <b>Heat Island Effect, Roof</b>   | 1        |
|          |          | <b>1</b> | Credit 8   | <b>Light Pollution Reduction</b>  | 1        |

Yes ? No

**4** **1** **Water Efficiency** **5 Points**

|          |  |          |            |   |   |
|----------|--|----------|------------|---|---|
| <b>1</b> |  |          | Credit 1.1 | <b>Water Efficient Landscaping, Reduce by 50%</b>                   | 1 |
| <b>1</b> |  |          | Credit 1.2 | <b>Water Efficient Landscaping, No Potable Use or No Irrigation</b> | 1 |
|          |  | <b>1</b> | Credit 2   | <b>Innovative Wastewater Technologies</b>                           | 1 |
| <b>1</b> |  |          | Credit 3.1 | <b>Water Use Reduction, 20% Reduction</b>                           | 1 |
| <b>1</b> |  |          | Credit 3.2 | <b>Water Use Reduction, 30% Reduction</b>                           | 1 |

Yes ? No

**2** **3** **15** **Energy & Atmosphere** **17 Points**

|          |          |          |          |   |          |
|----------|----------|----------|----------|---|----------|
| <b>Y</b> |          |          | Prereq 1 | <b>Fundamental Commissioning of the Building Energy Systems</b> | Required |
| <b>Y</b> |          |          | Prereq 2 | <b>Minimum Energy Performance</b>                               | Required |
| <b>Y</b> |          |          | Prereq 3 | <b>Fundamental Refrigerant Management</b>                       | Required |
|          | <b>2</b> | <b>8</b> | Credit 1 | <b>Optimize Energy Performance</b>                              | 1 to 10  |
|          |          | <b>6</b> | Credit 2 | <b>On-Site Renewable Energy</b>                                 | 1 to 3   |
| <b>1</b> |          |          | Credit 3 | <b>Enhanced Commissioning</b>                                   | 1        |
| <b>1</b> |          |          | Credit 4 | <b>Enhanced Refrigerant Management</b>                          | 1        |
|          |          | <b>1</b> | Credit 5 | <b>Measurement &amp; Verification</b>                           | 1        |
|          | <b>1</b> |          | Credit 6 | <b>Green Power</b>  | 1        |

continued...

TABLE 16: LEED NC V.2.2 Checklist for the SLCC.



LEED-NC

**LEED-NC Version 2.2 Registered Project Checklist**

Gallaudet University SLCC  
Washington, DC

Yes ? No

**6 1 6 Materials & Resources 13 Points**

| Y |   |  |  |   |            |  |  |          |
|---|---|--|--|---|------------|--|--|----------|
|   |   |  |  |   | Prereq 1   | <b>Storage &amp; Collection of Recyclables</b>                             |  | Required |
|   |   |  |  | 1 | Credit 1.1 | <b>Building Reuse</b> , Maintain 75% of Existing Walls, Floors & Roof      |  | 1        |
|   |   |  |  | 1 | Credit 1.2 | <b>Building Reuse</b> , Maintain 100% of Existing Walls, Floors & Roof     |  | 1        |
|   |   |  |  | 1 | Credit 1.3 | <b>Building Reuse</b> , Maintain 50% of Interior Non-Structural Elements   |  | 1        |
| 1 |   |  |  |   | Credit 2.1 | <b>Construction Waste Management</b> , Divert 50% from Disposal            |  | 1        |
| 1 |   |  |  |   | Credit 2.2 | <b>Construction Waste Management</b> , Divert 75% from Disposal            |  | 1        |
|   |   |  |  |   | Credit 3.1 | <b>Materials Reuse</b> , 5%  |  | 1        |
|   |   |  |  |   | Credit 3.2 | <b>Materials Reuse</b> , 10%   |  | 1        |
| 1 |   |  |  |   | Credit 4.1 | <b>Recycled Content</b> , 10% (post-consumer + ½ pre-consumer)             |  | 1        |
| 1 |   |  |  |   | Credit 4.2 | <b>Recycled Content</b> , 20% (post-consumer + ½ pre-consumer)             |  | 1        |
| 1 |   |  |  |   | Credit 5.1 | <b>Regional Materials</b> , 10% Extracted, Processed & Manufactured Region |  | 1        |
| 1 |   |  |  |   | Credit 5.2 | <b>Regional Materials</b> , 20% Extracted, Processed & Manufactured Region |  | 1        |
|   |   |  |  |   | Credit 6   | <b>Rapidly Renewable Materials</b>   |  | 1        |
|   | 1 |  |  |   | Credit 7   | <b>Certified Wood</b>  |  | 1        |

Yes ? No

**6 1 8 Indoor Environmental Quality 15 Points**

| Y |   |  |  |   |            |   |  |          |
|---|---|--|--|---|------------|---|--|----------|
|   |   |  |  |   | Prereq 1   | <b>Minimum IAQ Performance</b>                                      |  | Required |
|   |   |  |  |   | Prereq 2   | <b>Environmental Tobacco Smoke (ETS) Control</b>                    |  | Required |
|   |   |  |  | 1 | Credit 1   | <b>Outdoor Air Delivery Monitoring</b>                              |  | 1        |
|   |   |  |  | 1 | Credit 2   | <b>Increased Ventilation</b>  |  | 1        |
| 1 |   |  |  |   | Credit 3.1 | <b>Construction IAQ Management Plan</b> , During Construction       |  | 1        |
|   | 1 |  |  |   | Credit 3.2 | <b>Construction IAQ Management Plan</b> , Before Occupancy          |  | 1        |
| 1 |   |  |  |   | Credit 4.1 | <b>Low-Emitting Materials</b> , Adhesives & Sealants                |  | 1        |
| 1 |   |  |  |   | Credit 4.2 | <b>Low-Emitting Materials</b> , Paints & Coatings                   |  | 1        |
| 1 |   |  |  |   | Credit 4.3 | <b>Low-Emitting Materials</b> , Carpet Systems                      |  | 1        |
| 1 |   |  |  |   | Credit 4.4 | <b>Low-Emitting Materials</b> , Composite Wood & Agrifiber Products |  | 1        |
| 1 |   |  |  |   | Credit 5   | <b>Indoor Chemical &amp; Pollutant Source Control</b>               |  | 1        |
|   |   |  |  |   | Credit 6.1 | <b>Controllability of Systems</b> , Lighting                        |  | 1        |
|   |   |  |  |   | Credit 6.2 | <b>Controllability of Systems</b> , Thermal Comfort                 |  | 1        |
|   |   |  |  |   | Credit 7.1 | <b>Thermal Comfort</b> , Design                                     |  | 1        |
|   |   |  |  |   | Credit 7.2 | <b>Thermal Comfort</b> , Verification                               |  | 1        |
|   |   |  |  |   | Credit 8.1 | <b>Daylight &amp; Views</b> , Daylight 75% of Spaces                |  | 1        |
|   |   |  |  |   | Credit 8.2 | <b>Daylight &amp; Views</b> , Views for 90% of Spaces               |  | 1        |

TABLE 16: LEED NC V.2.2 Checklist for the SLCC (continued).



LEED-NC

**LEED-NC Version 2.2 Registered Project Checklist**

Gallaudet University SLCC  
Washington, DC

Yes ? No

|   |   |  |          |
|---|---|--|----------|
| 2 | 3 | <b>Innovation &amp; Design Process</b> | 5 Points |
|---|---|--|----------|

|   |  |   |  |   |
|---|--|---|--|---|
| 1 |  |   | Credit 1.1 <b>Innovation in Design:</b> Educational Case Study | 1 |
|   |  | 1 | Credit 1.2 <b>Innovation in Design:</b> Provide Specific Title | 1 |
|   |  | 1 | Credit 1.3 <b>Innovation in Design:</b> Provide Specific Title | 1 |
|   |  | 1 | Credit 1.4 <b>Innovation in Design:</b> Provide Specific Title | 1 |
| 1 |  |   | Credit 2 <b>LEED® Accredited Professional</b>                  | 1 |

Yes ? No

|    |   |    |   |           |
|----|---|----|---|-----------|
| 28 | 6 | 38 | <b>Project Totals (pre-certification estimates)</b> | 69 Points |
|----|---|----|---|-----------|

**Certified** 26-32 points **Silver** 33-38 points **Gold** 39-51 points **Platinum** 52-69 points

TABLE 16: LEED NC V.2.2 Checklist for the SLCC (continued).

**MECHANICAL SYSTEM DISCUSSION**

An analysis by the primary MEP engineers at SmithGroup found that two (2) possible EA Credit 1: Optimum Energy Performance points could be earned. Below are their results in Table 17.

| Energy & Cost Summary by Fuel | DEC'' Use             | DEC'' Cost      | ECB' Use              | ECB' Cost        | DEC'' / ECB' |        |
|-------------------------------|-----------------------|-----------------|-----------------------|------------------|--------------|--------|
|                               | [10 <sup>3</sup> Btu] | [\$]            | [10 <sup>3</sup> Btu] | [\$]             | Energy %     | Cost % |
| Electricity                   | 3,358,728             | \$88,989        | 4,266,915             | \$113,051        | 78.7%        | 78.7%  |
| Oil                           | 624,921               | \$8,655         | 1,057,210             | \$14,642         | 59.1%        | 59.1%  |
| <b>Total</b>                  | <b>3,983,649</b>      | <b>\$97,644</b> | <b>5,324,125</b>      | <b>\$127,693</b> |              |        |

**Percent Savings = 100 x (ECB' \$ - DEC'' \$) / ECB' \$ = 23.5%**

**Credit 1 Points Earned = 2**

TABLE 17: Design energy use versus Energy Cost Budget of SLCC.



## LOST "RENTABLE" SPACE

The goal of major new construction on a college campus is to provide state-of-the-art facilities to advance learning and research. Unlike a business such as a realtor or property manager, no profit is expected from occupancy of the building. Still, mechanical space is minimized above grade in order to maximize "useable" space. Instead, mechanical spaces are congregated either below grade or on the roof.

The SLCC follows this basic building design principle while addressing specific design goals. All AHUs are located in the basement, as are the emergency generator, switchboard, etc. Mechanical space on higher floors is limited to three shafts, a handful of closets, and plenum space between floors. With two lounges on the third floor of the atrium overlooking the classroom wing roof, no equipment is permitted on that roof. Instead, exhaust fans are hidden in a portico. Exhaust fans on the third floor roof are also hidden from view on the ground or from within the building.

As a result the total lost "rentable" space in the SLCC is 12900 SF, or 15.5% of the building area (see Table 18). However, the vast majority of this space is located in the basement. Lost "rentable" space above grade counts for only 1048 SF, or 1.5% of above grade floor area (see Table 19).

| Total Lost "Rentable" Space |              |                 |
|-----------------------------|--------------|-----------------|
| Space Type                  | Area [SF]    | % Building Area |
| Entire Building             | 87000        | 100.0%          |
| Mech./Elec. Equipment Space | 12108        | 13.9%           |
| Shaft Space                 | 792          | 0.9%            |
| <b>Total</b>                | <b>12900</b> | <b>14.8%</b>    |

TABLE 18: The proportions of mechanical space versus total building area.

| Lost "Rentable" Space Above Grade |             |                 |
|-----------------------------------|-------------|-----------------|
| Space Type                        | Area [SF]   | % Building Area |
| Floor Area Above Grade            | 67978       | 100.0%          |
| Mech./Elec. Equipment Space       | 256         | 0.4%            |
| Shaft Space                       | 792         | 1.2%            |
| <b>Total</b>                      | <b>1048</b> | <b>1.5%</b>     |

TABLE 19: The proportions of mechanical space versus building area on main floors.

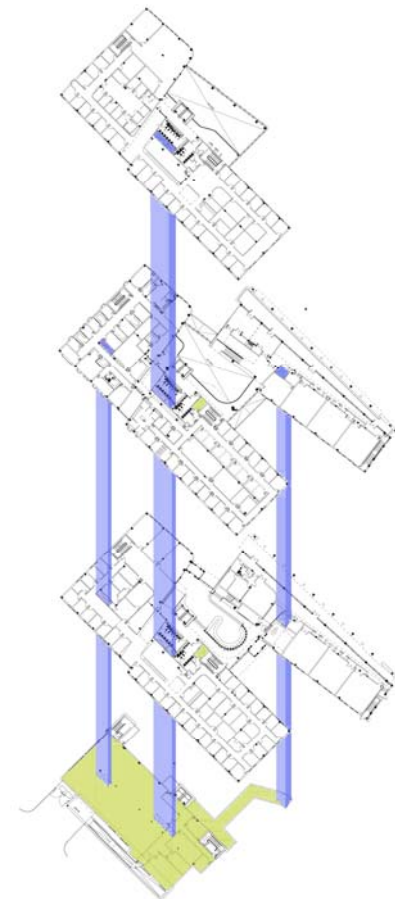

FIGURE 10: Orientation of mechanical space in the SLCC.

## MECHANICAL SYSTEM FIRST COST ANALYSIS

The construction documents phase of the SLCC design was completed in September 2006 and the project was opened for bidding. The 100% CD total first cost estimates for the design can not be released at this time because the general contractor has not been selected. However, full estimates were performed at the 60% CD Submission by Heery International – Construction Manager for SLCC – and International Consultants (ICI).

The total project costs range from \$22.95M to \$24.05M, with the CSI Division 15 costs ranging from \$3.48M to \$3.87M. The average mechanical system cost for the SLCC is approximately 17.5% of the total cost (see Table 20, Figure 11).

| Gallaudet University SLCC 60% Construction Document Cost Estimate Comparison |                      |                  |           |                    |           |                 |              |                               |
|--|----------------------|------------------|-----------|--------------------|-----------|-----------------|--------------|-------------------------------|
| Division   | Description          | ICI <sup>†</sup> |           | Heery <sup>‡</sup> |           | Average Cost/SF | Average Cost | Average Portion of Total Cost |
|  |                      | Cost/SF          | Amount    | Cost/SF            | Amount    |                 |              |                               |
|  |                      | 88,432           |           | 87,704             |           |                 |              |                               |
| 1  | GENERAL REQUIREMENTS | 37.15            | 3,284,919 | 35.70              | 3,130,654 | 38.64           | 3,207,787    | 15.3%                         |
| 2  | SITE WORK/DEMO       | 21.02            | 1,858,674 | 20.76              | 1,820,980 | 22.16           | 1,839,827    | 8.8%                          |
| 3  | CONCRETE             | 16.86            | 1,490,948 | 16.30              | 1,429,608 | 17.59           | 1,460,278    | 7.0%                          |
| 4  | MASONRY              | 7.52             | 665,232   | 6.45               | 565,746   | 7.41            | 615,489      | 2.9%                          |
| 5  | METALS               | 29.98            | 2,651,078 | 26.41              | 2,316,251 | 29.91           | 2,483,665    | 11.8%                         |
| 6  | WOODS & PLASTICS     | 3.20             | 282,609   | 3.00               | 263,121   | 3.29            | 272,865      | 1.3%                          |
| 7  | MOISTURE PROTECTION  | 15.39            | 1,361,003 | 13.84              | 1,213,656 | 15.50           | 1,287,330    | 6.1%                          |
| 8  | DOORS & WINDOWS      | 16.20            | 1,432,475 | 14.24              | 1,249,024 | 16.15           | 1,340,750    | 6.4%                          |
| 9  | FINISHES             | 21.95            | 1,941,193 | 26.76              | 2,347,035 | 25.82           | 2,144,114    | 10.2%                         |
| 10   | SPECIALTIES          | 1.81             | 159,935   | 1.83               | 160,236   | 1.93            | 160,086      | 0.8%                          |
| 11   | EQUIPMENT            | 0.08             | 7,450     | 0.27               | 23,500    | 0.19            | 15,475       | 0.1%                          |
| 12   | FURNISHINGS          |                  | 0         | 0.51               | 44,648    | 0.27            | 22,324       | 0.1%                          |
| 13   | SPECIAL CONSTRUCTION |                  | 0         |                    | 0         | 0.00            | 0            | 0.0%                          |
| 14   | CONVEYING SYSTEMS    | 3.05             | 270,000   | 3.08               | 270,000   | 3.25            | 270,000      | 1.3%                          |
| 15   | MECHANICAL           | 43.81            | 3,874,102 | 39.71              | 3,483,011 | 44.31           | 3,678,557    | 17.5%                         |
| 16   | ELECTRICAL           | 25.50            | 2,254,854 | 24.10              | 2,113,331 | 26.31           | 2,184,093    | 10.4%                         |

|              |               |                   |               |                   |                 |                   |
|--------------|---------------|-------------------|---------------|-------------------|-----------------|-------------------|
| Subtotal     |               | 21,534,472        |               | 20,430,801        |                 | 20,982,637        |
| Contingency  | 5%            | 1,076,724         | 5%            | 1,021,540         | 5%              | 1,049,132         |
| Subtotal     |               | 22,611,196        |               | 21,452,341        |                 | 22,031,768        |
| Escalation   | 6.7%          | 1,442,810         | 7%            | 1,501,664         | 7%              | 1,542,224         |
| <b>Total</b> | <b>272.01</b> | <b>24,054,006</b> | <b>261.72</b> | <b>22,954,005</b> | <b>267.6794</b> | <b>23,573,992</b> |

TABLE 20: Mechanical first cost versus total building construction cost.

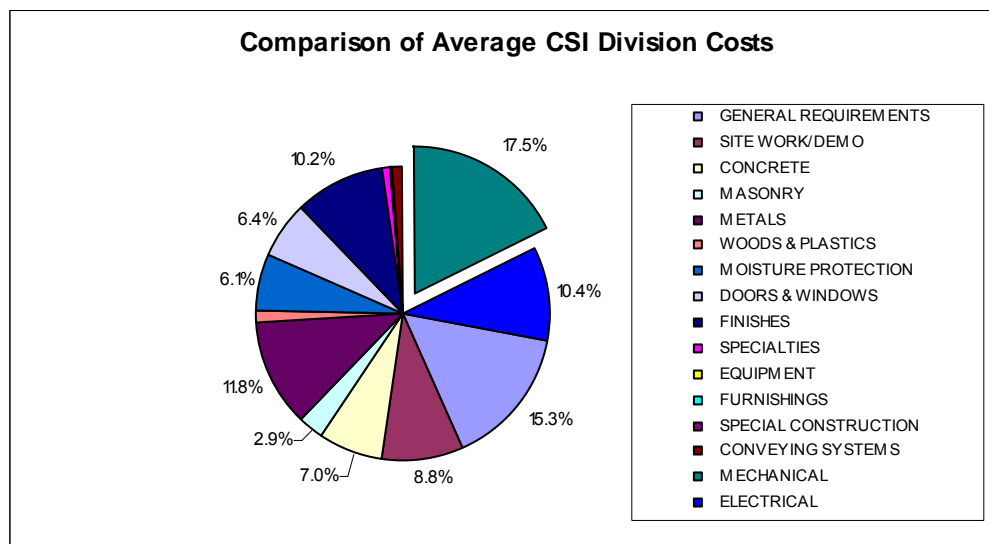

FIGURE 11: Mechanical first cost versus total building construction cost.



## MECHANICAL SYSTEM OPERATION COST ANALYSIS

The operational cost of the system includes both energy cost and maintenance. The estimates for the annual energy use cost by the HAP model are likely to be incorrect and further manipulation of the model is necessary. These results are far from the calculated annual energy cost of \$97,644 estimated by the energy model produced by the primary MEP engineers (see Table 17). A complete life cycle cost evaluation will be conducted in the final part of this thesis and will address the mechanical system first cost and operation cost.

| Annual Energy Costs |                 |
|---------------------|-----------------|
| Air System Fans     | \$2,239         |
| Cooling             | \$0             |
| Heating             | \$567           |
| Pumps               | \$1,796         |
| HVAC Subtotal       | \$4,602         |
| Lights              | \$4,898         |
| Electric Equipment  | \$3,715         |
| Non-HVAC Subtotal   | \$8,613         |
| <b>Grand Total</b>  | <b>\$13,215</b> |

TABLE 21: HAP Model results for Annual Energy Costs.

| Annual Energy Cost/SF |                |
|-----------------------|----------------|
| Air System Fans       | \$0.033        |
| Cooling               | \$0.000        |
| Heating               | \$0.008        |
| Pumps                 | \$0.026        |
| HVAC Subtotal         | \$0.067        |
| Lights                | \$0.072        |
| Electric Equipment    | \$0.055        |
| Non-HVAC Subtotal     | \$0.127        |
| <b>Grand Total</b>    | <b>\$0.194</b> |

TABLE 22: HAP Model results for Annual Energy Costs per Unit Floor Area.

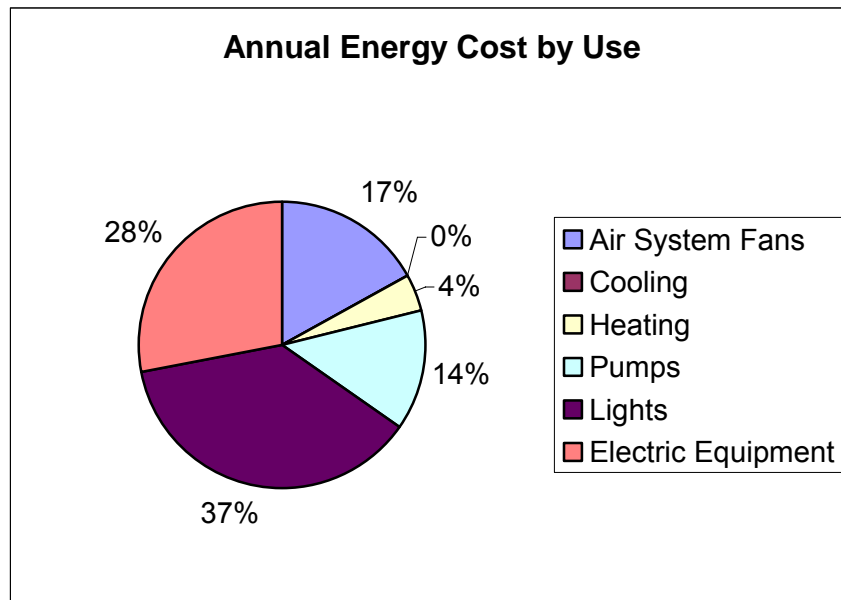

FIGURE 12: Energy use cost versus total building energy use cost.

## DESIGN CRITIQUE

The mechanical system design for the SLCC is straightforward and effectively tailored to the conditions of the site. With chilled water and steam service from the campus utilities no plant was needed in the building itself. Instead this chilled water is directly delivered to the cooling coils that use it, and thermal energy in the steam is transferred to heating hot water and domestic hot water with heat exchangers. The division of the air side mechanical system for the facility into six (6) distinct zones allows flexibility and independence based on occupancy schedules. VAV boxes allow controllability of the system for each zone. FCUs, unit heaters, and a CRAC unit account for the unoccupied spaces and reduce the amount of energy used to heat and cool these spaces.

The building construction and layout generally works to the advantage of the mechanical system. The envelope meets ASHRAE Std. 90.1 criteria for construction and glazing area. Beyond that, the majority of the glazing is on the north, east and west facades thus reducing solar heat gain. Also, the roof is covered with a highly reflective roofing membrane to reduce the absorption of solar radiation. Within the building the MER and other support spaces are generously sized and there is reasonable access to all equipment for maintenance. Three shafts allow for air distribution to and from the MER and to exhaust fans on the roof. These shafts are adequately sized, though they take floor space away from the program of the building. Corridors are packed with ducts and VAV boxes and coordination in these spaces is particularly difficult, especially for maintenance access. Also, many VAV boxes could not fit in the corridors and are located in occupied spaces, thus compromising the specified noise criteria for these spaces. Also, the use of VAV fan boxes increases noise levels in the acoustically sensitive spaces such as the audiology labs and therapy rooms. While sound attenuators are used, they act as a band-aid rather than a solution to this problem.

The evaluation of ventilation requirements in the first technical report found conflicting results. The SLCC was designed to ASHRAE Std. 62.1-1999 requirements rather than the 2004 criteria. The earlier standard provided an occupant density calculation where the entire outdoor air requirement was based on space population for each occupancy type. The 2004 version calls for separate population and floor area components to the overall outdoor air requirement. Based on this 2004 standard, the calculations find that five of the six AHUs serving the SLCC do not meet the minimum requirements from ASHRAE Std. 62.1. AHU – 1 provides approximately 24% excess outdoor air to the spaces it serves. Overall, however, the designed HVAC system provides more than 30% less outdoor air than is necessary per Std. 62.1. Other discrepancies resulted from assumptions made in the calculations and which spaces controlled the design based on the primary outdoor air fraction.

The calculations in the building system energy report found that the SLCC meets the minimum requirements from ASHRAE Std. 90.1-2004 for building envelope and lighting efficiency. This is considering that the building is only designed to 1999 criteria. Also the overall SLCC design would earn enough points to gain a LEED Certified Rating. However, the building energy use is only potentially 23% less than the energy cost budget building which may earn two (2) of the ten (10) possible EA Credit 1 points.

The cost of the system is approximately \$3.6M, or 17.5% of the total project cost. This may be slightly lower than for a typical building because no chilled water or steam plant was necessary for the building. As far as the operation costs, the Carrier HAP model made for the building system energy report shows some illogical discrepancies compared to the models performed by the primary MEP engineers. Based on the assumption that the Trane Trace model developed by the MEP engineers is correct, the SLCC consumes just under 4M MBH annually for an operation cost of \$97,644/yr where as the budget building consumes over 5.3M MBH for an annual operation cost of \$127,693/yr. Considering that the building does not include the steam and chilled water production, this is a sizeable reduction in energy consumption.

Overall the design of the SLCC mechanical system is efficient and practical. Energy saving equipment such as variable speed drives for fan and pump motors and energy saving techniques such as zoning help reduce total energy consumption. Also, the building envelope, glazing, and roofing decisions reduce energy lost/gained from the environment. However, the designers do not guarantee that the two (2) EA Credit 1 points will be earned. Another problem is that coordination with the larger size of ducts and confined plenums in corridors has led to some access and acoustical issues. The goal for this thesis will be to improve the energy efficiency of the building and to address these acoustic issues.

## RESOURCES

2005 ASHRAE Handbook of Fundamentals – *HVAC Applications*. ASHRAE, Inc. Atlanta, GA. 2005.

ANSI/ASHRAE Standard 62.1-2004 – *Ventilation for Acceptable Indoor Air Quality*. ASHRAE, Inc. Atlanta, GA. 2004.

ANSI/ASHRAE Standard 90.1-2004 – *Energy Standard for Buildings*. ASHRAE, Inc. Atlanta, GA. 2004.

Colorado Energy, "R-Values Table." 21 Mar. 2005. Visited 25 Oct. 2006.  
<http://www.coloradoenergy.org/procorner/stuff/r-values.htm>

LEED-NC V2.2 – *Reference Guide for New Construction and Major Renovations*. U.S. Green Building Council, Washington, DC. 2005.

Murphy, Patrick. *Technical Report 1: ASHRAE Standard 62.1-2004 Ventilation Compliance*. 6 Oct. 2006.  
<<http://www.arche.psu.edu/thesis/eportfolio/2007/portfolios/PBM119/tech-assign.htm>>

Murphy, Patrick. *Technical Report 2: Building Energy Analysis per ASHRAE Standard 90.1-2004 and LEED-NC V2.2*. 30 Oct. 2006.  
<<http://www.arche.psu.edu/thesis/eportfolio/2007/portfolios/PBM119/tech-assign.htm>>

Pepco, "Rate Schedules for Electric Service in the District of Columbia." 1 Jan. 2005.  
Visited 28 Oct. 2006. [http://www.pepco.com/\\_res/documents/dc\\_rate-schedules.pdf](http://www.pepco.com/_res/documents/dc_rate-schedules.pdf)

*Sorenson Language and Communication Center: 10% Construction Documents*. SmithGroup, Inc. Washington, DC. 1 Sept 2006.